



outline **outlinearray**

butterfly

HI-PACK C.D.H. 483 &
LOW-PACK C.D.L. 1815

Launched on the market at the beginning of **2003** on the occasion of Outline's 30th anniversary, the **Butterfly** is now one of the top five "stars" at world level in the field of vertical Line Arrays for sound reinforcement of all kinds and dimensions (arena tours, stadia, theatres,

indoor sports venues and more). Later nicknamed "**Outlinearray**" by FOH and system engineers as well as opinion leaders, Butterfly has earned an excellent reputation among the most respected rental companies worldwide (particularly in the UK and the USA), who use

HI-PACKS C.D.H. 483

The C.D.H. 483 Hi-Pack is the Butterfly system's element for mid-low, mid and high frequency reproduction. Weighing just 34 kg, the cabinet has an unmistakable shape (the only one among current line array systems covered by an international patent) which brings to mind the butterfly from which it takes its name, thanks to the triangular opening in the upper and lower "sides". This original design solution favours the optimum coupling of array elements up to the highest frequencies, keeping the distance between the sources as short as possible and at the same time providing them with a continuous loading 'baffle'. Unlike other units, Butterfly's shape doesn't contrast with the cabinet's technical operation, so doesn't accentuate any diffraction or alteration of mid/high response.

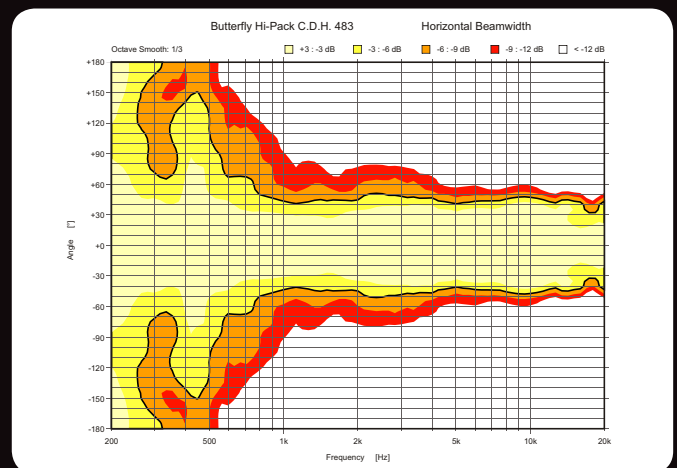
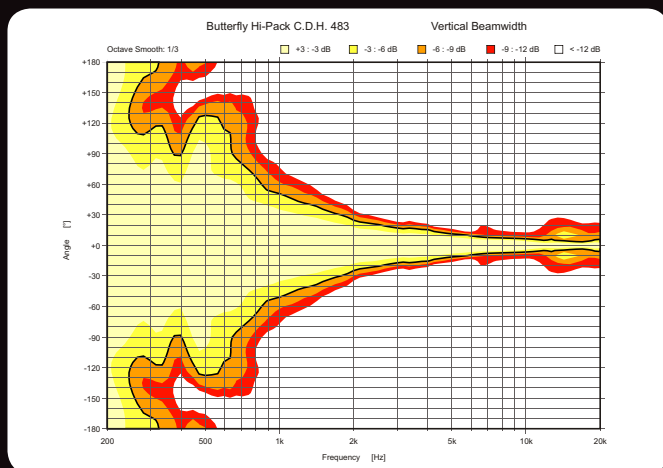

LOW-PACKS C.D.L. 1815

The C.D.L. 1815 Low-Pack is the Butterfly system's low frequency element. To all effects, it's an enclosure built with the criteria necessary for forming a real low frequency Vertical Line Array. It weighs just 46 kg, and its dimensions are the same as two C.D.H. 483 Hi-Packs one above the other. Being fitted with the same flying hardware, it's therefore completely compatible and able to be perfectly combined with the latter.

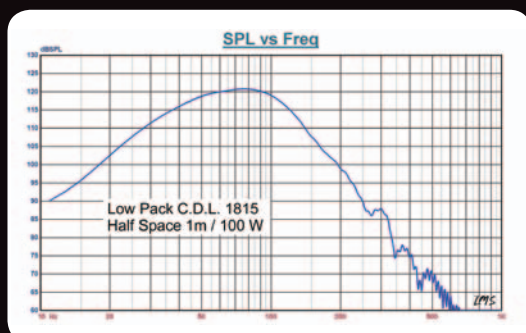

it as a valuable work tool on a day-to-day basis. A few words on sonic quality: its **precision**, described by some as **"surgical"**, its **"formidable" intelligibility**, **"superior" headroom**, **total lack of "over-aggressiveness"**, **aptitude for naturalness in sound reproduction** (to the point that

has been described as **"the planet's best hi-fi system"**), enormous SPL in spite of its **"small form factor"** and **"feather-light" weight** are just some of the definitions accumulated by Outline Butterfly in the course of its many years' work in the field.

HF SECTION AND D.P.R.W.G. DEVICE

The high frequency section of the Butterfly system is equipped with a 3" (1.41" throat) compression driver coupled with a D.P.R.W.G. (Double Parabolic Reflective Wave Guide) device, another Outline invention for which an international patent has been applied for. The result of three years of research and tests, the D.P.R.W.G. is a really original device and is geometrically based entirely on precise mathematic calculations. It has the job of taking a circular

planar (flat) wavefront emitted by the source at its input (e.g. that of a compression driver) and transforming it into a rectangular planar wavefront at its output, keeping signal paths identical from every emission point of the source.

The rectangular planar wavefront thus obtained can be loaded by an appropriate horn or waveguide to ensure the necessary coverage. (*)

MID-BASS AND MID SECTION

The C.D.H. 483 is a three-section element/enclosure designed for biamping. As well as a 3" compression driver, it's equipped with four high-efficiency 8" mid woofers: two band-pass loaded (110 ÷ 400Hz) and two reflex high-pass (110 ÷ 1250Hz) loaded by the sides of a waveguide with a 90° dispersion angle. These two sections are connected in parallel without any type of passive crossover, so can both be powered using one amplifier. By means of the appropriate upper mechanical filter of the first band-pass section, obtained with the precise restricting design of the resonance chambers and the respective tuning, emission phase has been shifted, enabling the energy in the portion of band reproduced by both sections together to be doubled. This peculiarity, at present an exclusive feature, enables to make up for the lack of power in the mid/low frequencies typical of other line array elements whose compact dimensions are comparable to those of Butterfly C.D.H. 483 High-Packs.

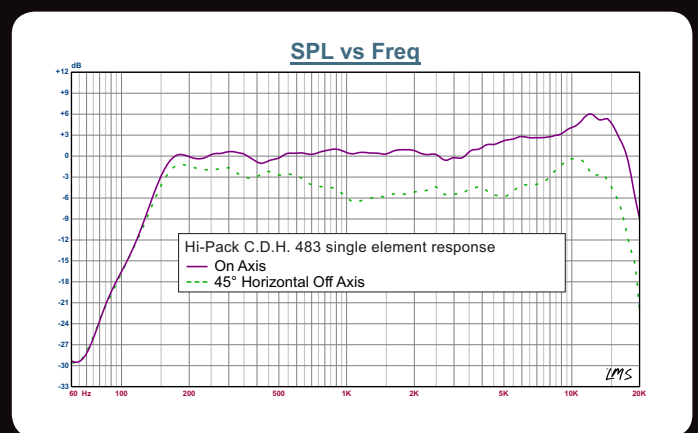

Original component positioning has resulted in extremely uniform on and off-axis horizontal response over a very wide range of frequencies. Measurements at 45° show how directivity is constant from approximately 700 Hz up to the highest frequencies. Looking at the diagrams, it's impossible to see where the crossover frequency is, which goes to show that the components are perfectly in phase.

CARDIOID OR HYPERCARDIOID DISPERSION

The C.D.L. 1815 Low-Pack is equipped with a 18" woofer for front emission and a 15" woofer inside the box, used to recreate the system's Cardioid or Hypercardioid dispersion. The two loudspeakers are powered by separate amplifiers. The diagram, related to the most useful cardioid configuration, shows the uniform reduction of rear emission for all frequency bands involved and the remarkable "front-to-back" ratio which,

from a minimum of 12dB at 120Hz (the suggested upper cut-off frequency) gives an attenuation of over 15dB on rear emission for all the other frequency bands (100, 80, 63, 50, 40 Hz). Applications have been made for Italian and international (PCT) patents for the C.D.L. 1815 Low-Pack too, supported by frequency response polar plots and a circuit diagram to make its original operating principle more easily understood. (*)

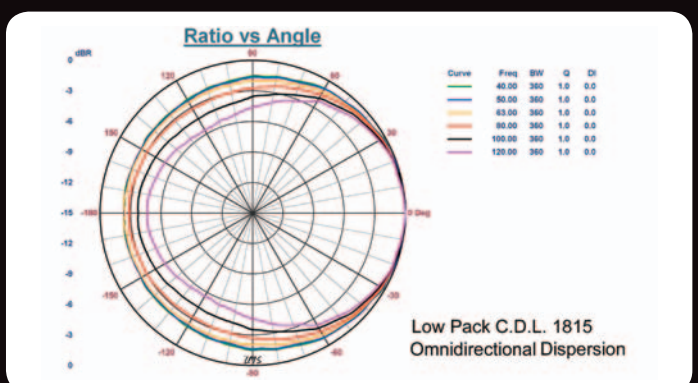
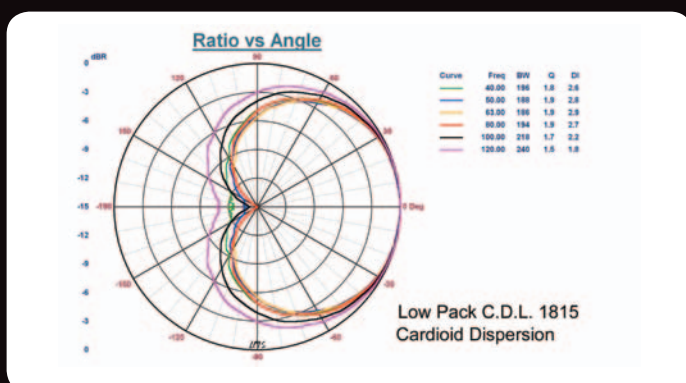

(*) Source: **Butterfly System White Paper** by **Guido Noselli**

BUILT-IN HARDWARE

Butterfly Hi-Pack and Low-Pack elements are both equipped with built-in flying hardware. This enables the angle between the elements to be adjusted with minimum increments of as little as 0.25 degrees. The dimensions and material used have enabled this hardware to be certified according to the strictest international norms, for flying an array of up to 32 C.D.H. 483 Hi-Packs at a height of approximately 8 metres and up to 24 C.D.L. 1815 Low-Packs in another array at a height of approximately 11.5 metres. As far as the positioning of the single elements is concerned, compared with all line arrays currently on the market, this flying system also has a matchless adjustment precision, as well as having an excellent load-bearing capacity and such compact dimensions as to enable it to be an integral part of each single element.

ID DESCRIPTION

- 1 Extension Frame Butterfly
- 2 Central (254 mm) support bar for A EXTFRM-BFLY-I
- 3 Central (332 mm) support bar for A EXTFRM-BFLY-I
- 4 Back connection bar to Frame
- 5 0.5° STEP - 0° START back connection bar
- 6 0.5° STEP - 0.25° START back connection bar
- 7 Side connection bar
- 8 Loudspeaker side connection bar for rope
- 9 Butterfly LOW-PACK
- 10 Extension Frame side connection bar for rope
- 11 Butterfly HI-PACK
- 12 Side connection bar to Frame
- 13 Central Mainframe Bfly

CODE

- A EXTFRM-BFLY-I
- A BAR-254
- A BAR-332
- A V568
- A V530A-B
- A V554A-B
- A V531
- A V552-553
- O BFLY-CDL1815
- A V557
- O BFLY-CDH483
- A V556
- A MFR-BFLY-I

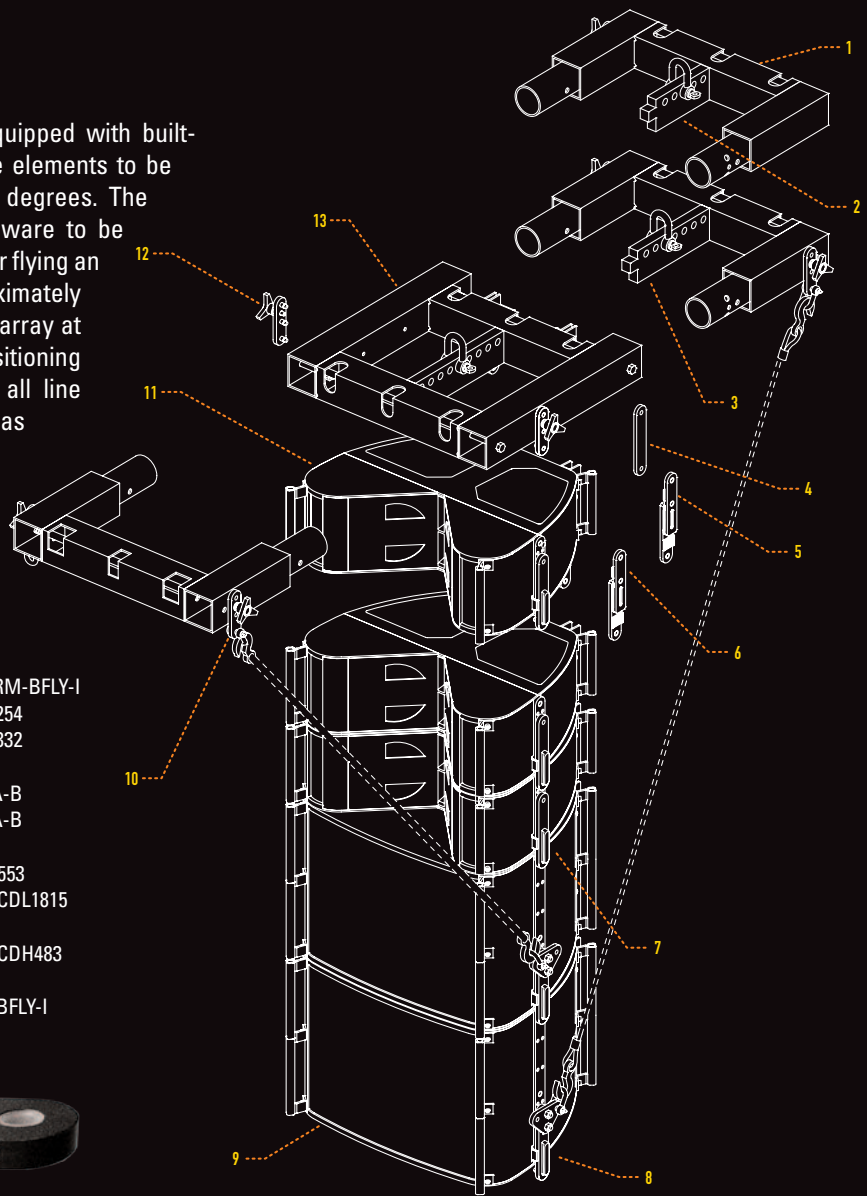

Close-up of the graduated load-bearing bar: it's designed to enable a setting increment of 0.25 degrees in the angle between array elements.



OUTLINE BUTTERFLIES AMPLIFY THE BIGGEST ROCK EVENT EVER HELD AT THE NEW WEMBLEY STADIUM:
THE FOO FIGHTERS CONCERTS - ATTENDANCE: 100.000 X DAY

OPENARRAY 3D SIMULATION SOFTWARE

OPENARRAY is the avant-garde control and 3D simulation software, written by Outline's R&D team.

It's a three dimensional software program that can predict the results expected from either a live performance or an installation of a wide range of Outline products, including all the Line Arrays and subwoofers models as well Outline's most popular point source systems. The result is a 'tool' able to guide PA system engineers through correct set-up procedure from an acoustic and mechanical point of view while fully respecting safety norms.

OPENARRAY greatly facilitates installation, setting and aiming of Line Array elements: the risk of poor results is thus drastically reduced. The technology behind **OPENARRAY** is based on a **GL platform** and features incredibly fast rendering time from input of data to final design.

OPENARRAY also has the ability to import DXF files, thus giving engineers a head start to final deployment of the intended system. This, and many other features, makes **OPENARRAY** one of the most exclusive product on the international scenario.

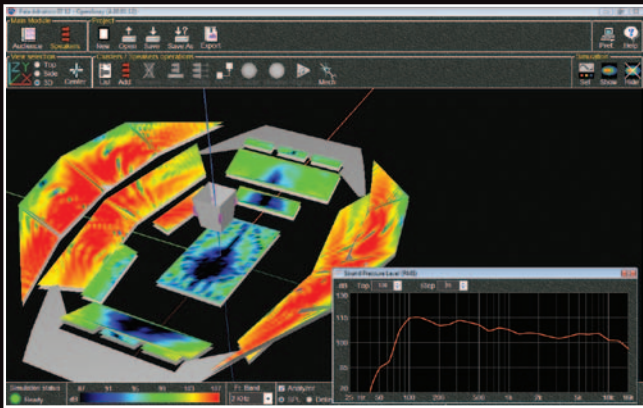

FIG. N° 1

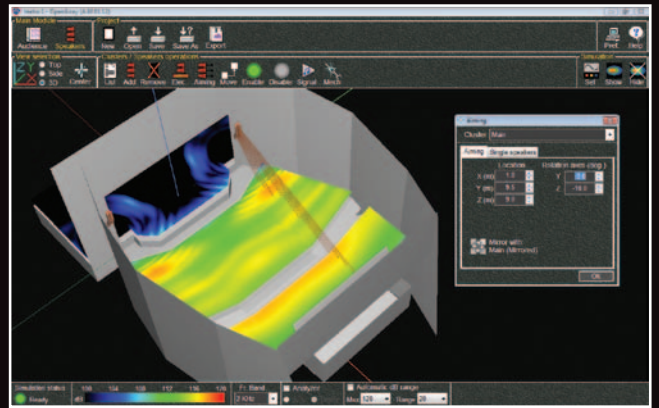

FIG. N° 2

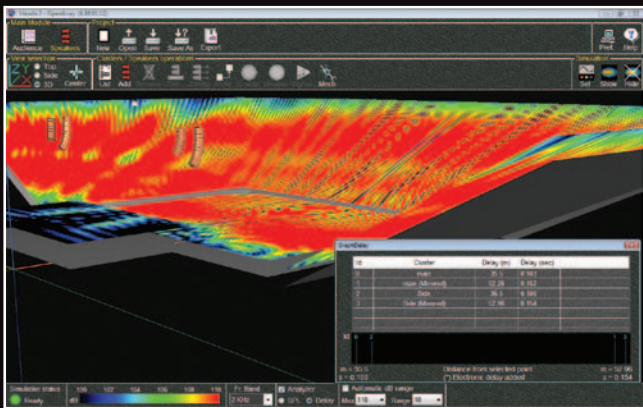

FIG. N° 3

FIG. N° 1 - MULTI-LEVEL INDOOR SPORTS ARENA

Sound reinforcement design for a multi-level indoor sports arena by means of the use of a centre cluster with 4 VLA (vertical line array) systems. Openarray 3D can import DXF files (the standard format for CAD-type files), even those regarding considerably complex venue layouts. The software enables to view the predicted SPL (sound pressure level) for each individual frequency. It also allows to check the frequency response selected at any point in the listening zone.

FIG. N° 2 - LOCATION > ROTATION > AIMING > MIRRORING

As in the example of the theatre shown in the illustration, Openarray 3D allows to position the VLA, rotate it on its vertical axis, aim it at the audience and, lastly, using the "Mirror" function, perfectly clone the other channels settings.

FIG. N° 3 - MULTI-ARRAY SYSTEM WITH "PHASOR SUMMATION"

As in the example of the arena shown in the illustration, Openarray 3D shows the different arrival times of the sound (delay) fed out by the various VLA in the point selected (in this case the signals are correlated).

FIG. N° 4 - SUBWOOFERS IN CARDIOID CONFIGURATION

Openarray 3D also ensures accurate simulations regarding "cardioid" configurations of enclosures used to reproduce low frequencies. The example in the illustration shows the SPL produced by 16 subwoofers in the aforementioned configuration at a frequency of 50 Hz.

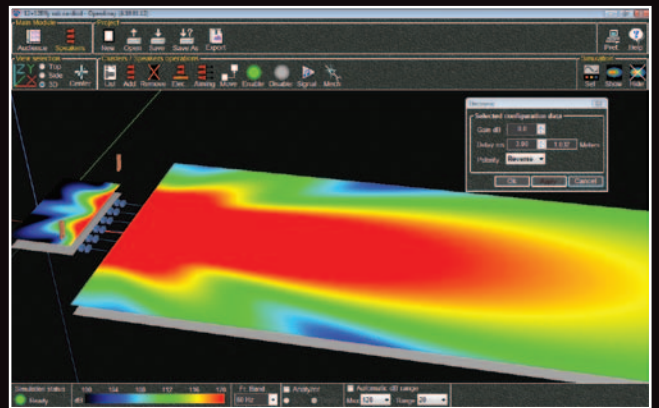

FIG. N° 4

FIG. N° 5 - MECHANICS, WEIGHTS, ANGLES

An accurate prediction of the angle between the elements, even if they are a combination of Hi-Packs and Low-packs, greatly facilitates "aiming" at the audience. Riggers are thus provided with all the geometric and mechanical data necessary for carrying out their work perfectly, without worrying about committing any serious mistakes. A diagram is created for each array, with all the parameters for flying according to limits set by international safety norms for suspended loads.

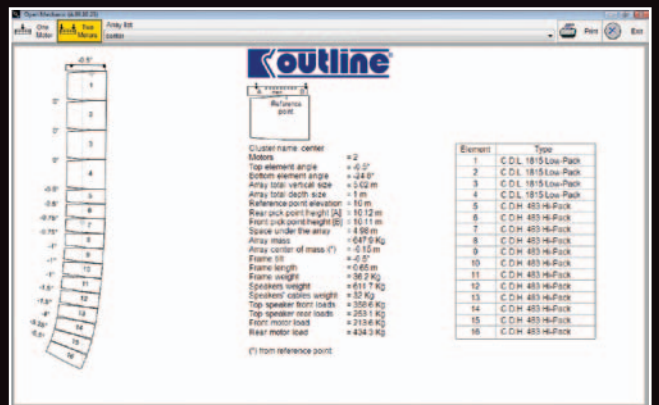

FIG. N° 5

HI-PACK C.D.H. 483

NUMBER OF SPEAKERS
LOW/MID
MID
HIGH

OPERATING CONFIGURATION
ENCLOSURE

FINISH
CONNECTORS
RIGGING HARDWARE
MAX DEGREE CABINET COUPLING
MAX FLYABLE ELEMENTS

FREQUENCY RESPONSE

Single element +/- 3dB
 Coupled array four units +/- 3dB

NOMINAL COVERAGE ANGLE -6dB

Horizontal
 Vertical

NOMINAL IMPEDANCE

Low/mid
 High

INPUT POWER RATING

(AES-Standard)
 High-pass filtered low/mid
 High

CALCULATED MAX SPL - 1m

(Single Unit - full space)

Low/mid
 High (8 kHz)

8-box array - Max SPL - 1m
 8-box flat array low/mid
 8-box flat array high (8 kHz)

SINGLE UNIT DIMENSIONS

Front Height	mm/kg	inches/pounds
Rear Height	240	9.45
Width	194	7.64
	700	27.56

5
 2x 8" NdFeB bandpass loaded woofers
 2x 8" Partially horn-loaded mid woofers
 1x 3" Diaphragm NdFeB, DPRWG (Double Parabolic Reflective Wave Guide) loaded compression driver
 Biamped, 3 sections (mid-bass section mechanically filtered)
 High impact exterior grade shaped composite plywood
 Textured scratchproof fire-retardant black paint
 2x Neutrik NL4
 Integrated high-load flying hardware and handles
 7.5° with 0.25° standard minimum increment
 32 - Height 7.76 m (25.46 ft) - Weight 1088 kg (2398 lb)

110 Hz ÷ 18 kHz
 80 Hz ÷ 18 kHz
 90°
 Depending on array height and curvature

4 ohms (min. 3.5 ohms)
 8 ohms (min. 8.3 ohms)

Continuous WRMS Calculated W peak + 6dB

800	3,200
120	480

Continuous Calculated +10dB Peak

128.5	138.5
131	141

Continuous Calculated +10dB Peak

146	156
146	156

SINGLE UNIT DIMENSIONS

Depth	mm/kg	inches/pounds
Net Weight	600	23.62
(Including flying hardware)	34	75

LOW-PACK C.D.L. 1815

NUMBER OF SPEAKERS
MAIN LOW
REVERSE LOW

OPERATING CONFIGURATION
ENCLOSURE

FINISH
CONNECTORS
RIGGING HARDWARE

MAX DEGREE CABINET COUPLING
MAX FLYABLE ELEMENTS

FREQUENCY RESPONSE

Single element +/- 3dB

COVERAGE ANGLE -6dB

Horizontal
 Vertical

BANDPASS NOMINAL IMPEDANCE

Main 18" (front)
 Reverse 15" (back)

INPUT POWER RATING

(AES-STANDARD)
 High-pass filtered front 18"
 High-pass filtered back 15"

CALCULATED MAX SPL - 1m

(Single Unit - half space)

Multiple Box Array Flyable Bass Units

8 Units - 1m full space

SINGLE UNIT DIMENSIONS

Front Height	mm/kg	inches/pounds
Rear Height	483	19.02
Width	437	17.20
	700	27.56

2
 1x 18" vented high-pass loaded woofer
 1x 15" vented bandpass loaded NdFeB woofer
 Biamped and electronically controlled
 High impact exterior grade shaped composite plywood
 Textured scratchproof fire-retardant black paint
 2x Neutrik NL4
 Butterfly Hi-Pack compatible;
 integrated flying hardware and handles
 7.5° with 0.25° minimum increments
 24 - Height 11.59 m (38 ft) - Weight 1104 kg (2434 lb)

40 Hz ÷ 120 Hz
 180°
 According to array height and position

5 ohms (min. 4.9 ohms)
 8 ohms (min. 7.9 ohms)

Continuous WRMS Calculated W peak + 6dB

1,000	4,000
350	1,400

Continuous Long Term Calculated +10dB Peak

132	142
-----	-----

Continuous Peak Calculated +10dB Peak

149	159
-----	-----

SINGLE UNIT DIMENSIONS

Depth	mm/kg	inches/pounds
Net Weight	600	23.62
(Including flying hardware)	46	101.4



OUTLINE ITALY

Tel.: ++39 030 35.81.341
 Fax ++39 030 35.80.431
 mail to: info@outline.it
 www.outline.it



OUTLINE NORTH AMERICA LLC

Tel.: 516 249 0013
 Fax: 516 249 8870
 Mob.: ++1 917 873 3602
 mail to: na_sales@outline.it